

Liquid Level Sensors

M-Series Magnetostrictive Sensors



Model USTD II
Underground Storage Tank Level Sensor
For Leak Detection and Inventory Monitoring

550980 A

Installation Instructions



Table of Contents:

1.0 USTD II Software Information	Page
1.1. Communication protocol	1
1.2. Communication timing	1
1.3. Command 02	2
1.4. USTD II command set	2
1.5. USTD II error codes	3
2.0 USTD II wiring information	
2.1. Safety limitations	3
2.2. Connection diagram of the connector and the pigtailed cable	4
2.3. Resistance table for proper network function	4
2.4. Shielding and transient protection	5

1.0 USTD II Software Information

1.1 Communication Protocol

The communication is based on a RS485 network which allows up to 32 transceivers to be connected. The transmission speed is 4800 baud. Each word consists of 11 bits; 1 start, 1 stop, 8 data and 1 even parity bit.

The communication follows a master/slave principle. All gauges operate in a passive mode until the master requests a certain action from one of them.

When an action is requested, the first byte the master sends is an address byte in the range of C0-FD hex. The second byte is a command byte which tells the addressed gauge what action to take.

For example C2 0A requests the following action:
"sensor name C2 measure the first float and send the result in 0.1 inch resolution.

First the addressed gauge sends an acknowledgement by repeating these two bytes (echo). Then the gauge performs the required action and sends the data as an ASCII string. To provide an efficient integrity test, the gauge calculates a checksum and sends it as a 5 digit ASCII decimal value to the master. This value is the 2's complement of the sum of the data string bytes (including STX and ETX). The master adds this value to the sum of the received bytes (except the echo) for a result of zero.

1.2 Communication Timing

The byte time is given by the transmission speed (4800 baud) as 2.3ms. The bytes can be transmitted without any additional delay between them, but if there is, it should not exceed 5ms. When the command byte is also transmitted, the master should disable its driver to allow the gauge to send the echo. The time between the end of command byte transmission and the echo can vary from 19ms to 25ms.

The time between the echo and the beginning of the data transmission can vary between zero (when the function is aborted because of an error) and TMAX which is given in the USTD II command set table on page two.

All specifications are subject to change. Please contact MTS for specifications that are critical to your needs. For additional information go to www.mtssensors.com.

1.3 Command 02

All gauges are delivered with the address C0. To configure your network of gauges, address C0 must be changed by using the command 02.

You can configure your network using two methods. Programming the network using the following method requires the serial number for each sensor (access code) that is mounted on each tank:

To select a single gauge, use address FF and command byte 02. An access code string (which is equal to the serial number and unique to each sensor), is transmitted by the master. The following is an example of the access code: <SOH>12345678<EOT>.

If a sensor receives its access code it responds with the current address <STX>192<ETX> (+ checksum) to flag that it is ready to receive the new address. Within 500ms the master can now transmit the new address for example <SOH>193<EOT> (C1). When the new address is successfully written in the sensors nonvolatile memory (EEPROM) the sensor transmits an <ACK> (+ checksum).

The second method is to reserve the address C0 for gauges that are added to the network. Then the gauges can be linked to the network one by one, while an intelligent software reads the access code in the device information of the newly added or replaced gauge (C0 4F) and uses this to program the desired address.

1.4 USTD II Command Set

Command code (hex) and name	Possible Answers	TMAX in ms
C0 01	C0 01 "STX DDA ETX"	115
FF 02 "SOH {access code} EOT" "SOH a a a EOT"	"STX a a a ETX" or no response "ACK" or no response	115 500
C0 0A Output level 1 (product) at 0.1 inch resolution	C0 0A "STX d d d d . d ETX" C0 0A "STX E 1 0 2 ETX"	500
C0 0B Output level 1 (product) at 0.01 inch resolution	C0 0B "STX d d d d . d d ETX" C0 0B "STX E 1 0 2 ETX"	500
C0 0C Output level 1 (product) at 0.001 inch resolution	C0 0C "STX d d d d . d d d ETX" C0 0C "STX E 1 0 2 ETX"	500
C0 10 Output level 1 (product) and level 2 (interface) at 0.1 inch resolution	C0 10 "STX d d d d . d : d d d d . d ETX" C0 10 "STX E 1 0 2 : E 1 0 2 ETX"	500
C0 11 Output level 1 (product) and level 2 (interface) at 0.01 inch resolution	C0 11 "STX d d d d . d d : d d d d . d d ETX" C0 11 "STX E 1 0 2 : E 1 0 2 ETX"	500
C0 12 Output level 1 (product) and level 2 (interface) at 0.001 inch resolution	C0 12 "STX d d d d . d d d : d d d d . d d d ETX" C0 12 "STX E 1 0 2 : E 1 0 2 ETX"	500
C0 19 Average temperature at 1 degree Fahrenheit resolution	C0 19 "STX d d d d ETX" C0 19 "STX E 2 0 1 ETX"	300
C0 1A Average temperature at 0.1 degree Fahrenheit resolution	C0 1A "STX d d d d . d ETX" C0 1A "STX E 2 0 1 ETX" C0 1A "STX E 2 12 ETX"	300
C0 1B Average temperature at 0.01 degree Fahrenheit	C0 1B "STX d d d d . d d ETX" C0 1B "STX E 2 0 1 ETX"	300
C0 1F Average and individual DT temperature at 1 degree Fahrenheit resolution	C0 1F "STX d d d d : d d d d : ... : d d d d ETX" C0 1F "STX E 2 0 1 : d d d d : ... : d d d d ETX" C0 1F "STX E 2 12 : d d d d : ... : d d d d ETX"	300
C0 20 Average and individual DT temperature at 0.1 degree Fahrenheit resolution	C0 20 "STX d d d d . d : d d d d . d : ... : d d d d . d ETX" C0 20 "STX E 2 0 1 : d d d d . d : ... : d d d d . d ETX" C0 20 "STX E 2 12 : d d d d . d : ... : d d d d . d ETX"	300
C0 21 Average and individual DT temperature at 0.01 degree Fahrenheit resolution	C0 21 "STX d d d d . d d : d d d d . d d : ... : d d d d . d d ETX" C0 21 "STX E 2 0 1 : d d d d . d d : ... : d d d d . d d ETX" C0 21 "STX E 2 12 : d d d d . d d : ... : d d d d . d d ETX"	300
C0 4D Read level offset data	C0 4D "STX d d d d . d d d : d d d d . d d d ETX"	115
C0 4F Read device info	C0 4F "STX O . N . = {ordering number} : F . N . = {factory number} : A . C . = {access code} : V 1 . v v v v ETX"	115
C0 57 "SOH c : d d d d . d d d EOT" Set offset for float c	C0 57 "STX c : d d d d . d d d ETX"	115

Notes:			
C0	gauge address byte	possible range :	C0 - FD
" "	includes ASCII strings		
a a a	address in characters	possible range :	192 - 255
d d d . d d d	numbers in characters	suppressed are:	leading zeros and positive sign (+)
{access code}	unique code, 8 ASCII characters (serial number)	example :	12345678
{ordering number}	see ordering documents, 13 ASCII characters	example :	USTDII - M256569
{serial number}	8 ASCII characters	example :	98010001

1.5 USTD Error Codes

- E102 - Missing float
A level request has been made with no level data returned.
- E212 - DT communication error.
A DT is shorted or open or has been set to 'not active'.
- E201 - No DT's programmed, DT's are not active or there are no DT's.

2.0 USTD Wiring Information

2.1 Safety Limitations

The USTD has a ATEX/PTB approval EEx ia IIB which allows the use on intrinsically safe circuits with the following limitations :

maximum voltage	$V_{max} \leq 28 \text{ V}$
sum of currents	$\Sigma I \leq 200 \text{ mA}$
sum of power	$\Sigma P \leq 1.3 \text{ W}$ for a maximum ambient temperature of 40 °C $\Sigma P \leq 1.2 \text{ W}$ for a maximum ambient temperature of 60 °C $\Sigma P \leq 1.0 \text{ W}$ for a maximum ambient temperature of 80 °C

The following tables show a small selection of possible barriers :
a) power supply (+24 V)

Supplier	Type	Maximum Voltage	Maximum Current	Maximum Power	Maximum Resistance	Number of Channels
STAHL	9001/01-280-165-101	28 V	165 mA	1155 mW	199Ω	1
STAHL	9001/01-280-110-101	28 V	110 mA	770 mW	293Ω	1
MTL	728+	28 V	93 mA	651 mW	340Ω	1
MTL	7028+	28 V	93 mA	651 mW	332Ω	1
MTL	7128+	28 V	93 mA	651 mW	342Ω	1

b) communication lines (TX/RX+ and TX/RX-)

Supplier	Type	Maximum Voltage	Maximum Current	Maximum Power	Maximum Resistance	Number of Channels
STAHL	9001/01-086-010-101	8.6 V	10 mA	21.5 mW	93Ω	1
STAHL	9002/11-120-024-001	12 V	24 mA	72 mW	1028Ω	2
MTL	764+	12 V	24 mA	72 mW	1075Ω	2

Example of a safety calculation for MTL 728+ barrier:

$$\begin{aligned}
 V_{max} &= 28 \text{ V} \\
 \Sigma I &= 93 \text{ mA} \\
 \Sigma P &= 651 \text{ mW} \quad \Rightarrow 80 \text{ °C allowed}
 \end{aligned}$$

2.2 Connection Diagram of the Connector and the Pigtail Cable

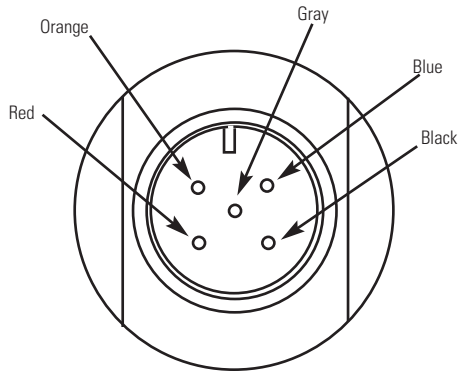

Wire Color	Signal
Red	24 V PWR
Black	0 V PWR
Gray	Earth GND
Blue	TXD RXD +
Orange	TDX RXD -

2.3 Resistance Table

The following table shows maximum resistances for the supply loop and for each communication line :

Number of Gauges on the Net	RPmax on 24V supply	RCmax
1	1305Ω	7560Ω
2	675Ω	3731Ω
3	459Ω	2466Ω
4	378Ω	1833Ω

Number of Gauges on the Net	RPmax on 24V supply	RCmax
5	252Ω	1456Ω
6	225Ω	1207Ω
7	216Ω	1027Ω
8	207Ω	893Ω

RP Resistance in the Power Supply Loop

Usually RP is the sum of the supply source resistance, the supply barrier resistance and two times the cable resistance. Note that the RPmax is given for a supply voltage of 24V, higher voltages would allow more resistance, lower voltages will allow less resistance.

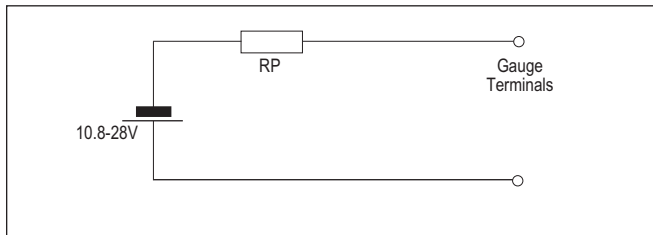

RC Resistance in Each Communication Line

Usually RC is the sum of the communication barrier resistance and the cable resistance. Note that the communication lines have to be symmetric, so that the difference between RC+ and RC- is less than 5%.

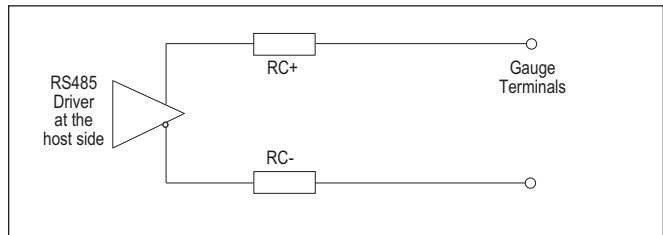

Example of a Resistance Calculation

Power Supply	24 .. 26V	EB 328-02 load regulation 10mV / 75 .. 175mA => Ri = 0.1Ω
barriers	+24 V TX/RX+ TX/RX- cable	STAHL 9001/01-280-165-10 STAHL 9001/01-086-010-10 STAHL 9001/01-086-010-10 ∅0.75mm ² 24Ω / km length 150m
supply loop	RP	= 0.1Ω + 199Ω + 3.6Ω + 3.6Ω = 206.3Ω => 8 sensors possible
comm. loop	RC	= 937Ω + 3.6Ω = 940.6Ω => 7 sensors possible

This configuration is effective with up to 7 sensors on the network. If the desired number is only slightly above what the calculation gives, you can verify the functionality by testing. It is recommended that you use additional resistors to test the configuration at 110% resistance.

As an example, 21Ω is inserted in the +24V line and 95Ω in each communication line. The network is then tested for proper function. If the network fails to function properly, you have to split the network. This means different barrier sets and cable for each network. The networks are connected on the safe side.

Using this method, up to 31 gauges can operate on one host communication port.

2.4 Shielding and Transient Protection

This drawing shows how to ground and shield the sensors.

Other circuits are possible but not covered by the PTB intrinsically safety approval and not tested for the CE label requirements.

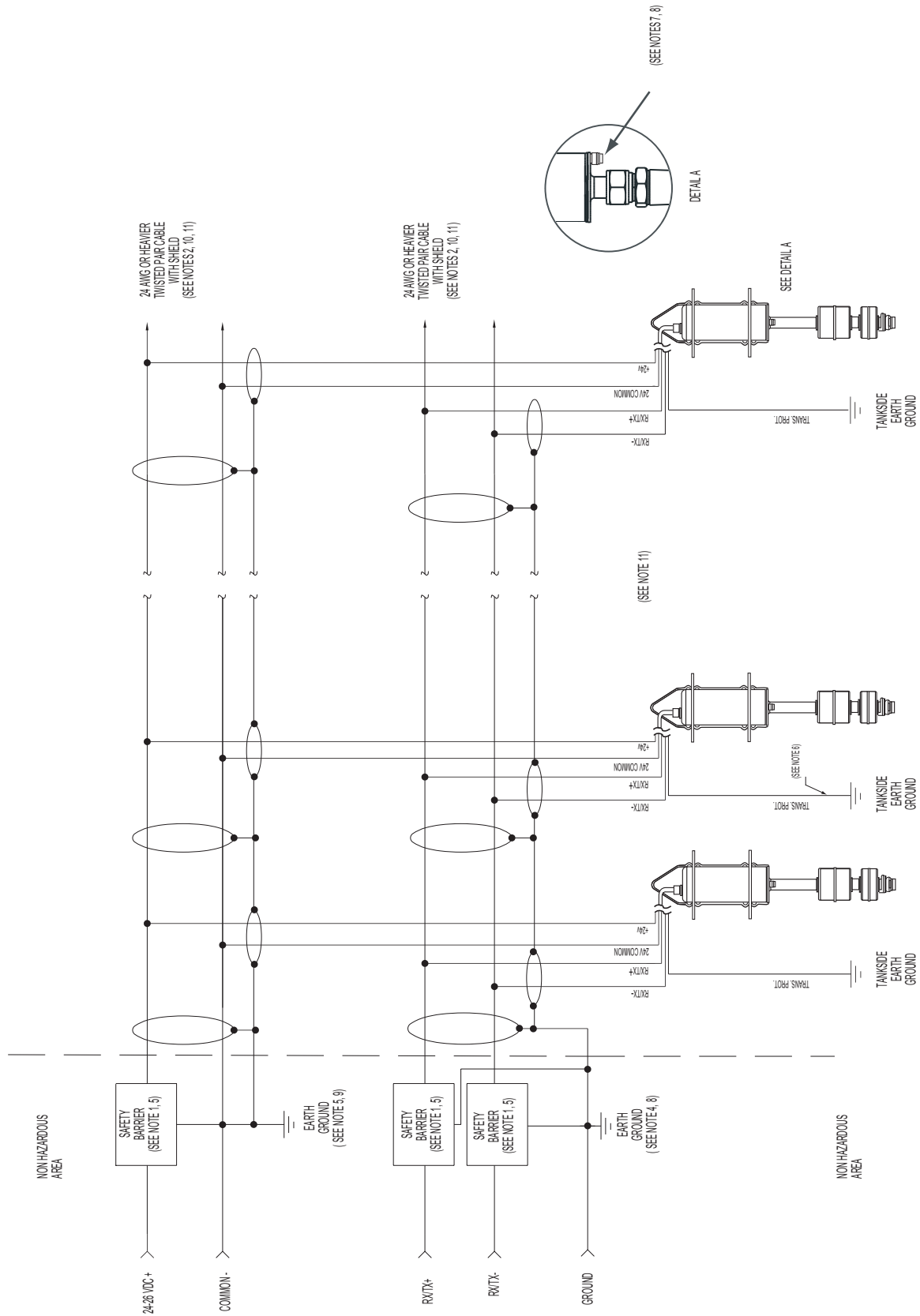

Notes:

1. Safety barriers are FMRC approved and/or ATEX certified (as applicable) with entity parameters and must be used in an approved configuration where the following conditions are met:
 - Voc, or Vt of the barrier combination is less than Vmax of the transmitter.
 - Isc, or It of the barrier combination is less than Imax of the transmitter.
 - Ca of the barrier combination is greater than the total Ci of the transmitters plus the cable capacitance.
 - La of the barrier combination is greater than the total Li of the transmitters plus the cable capacitance.Transmitter entity parameters:
Vmax = 28 V
Imax = 200 mA
Ci = 0
Li = 0
2. Power supply cable must be 24 AWG or heavier, shielded twisted pair cable. Cable capacitance must be less than 50 pF per foot. Cable shield is connected to system ground at safety barrier end only.
3. Communications cable must be 24 AWG or heavier, shielded twisted pair cable. Cable capacitance must be less than 24 pF per foot. Cable shield is connected to system ground at safety barrier end only.
4. The wire connection between earth ground and the safety barrier ground terminal must be less than 1 Ohm.
5. Maximum approved number of DDA gauges for intrinsically safe wiring networks is 8.
6. Connection to earth ground for transient protection circuitry.
7. Ground screw provided to connect gauge housing to earth ground.
8. The transducer frame shall be grounded to earth ground directly or through the equipment on which it is mounted and shall be at the same potential as the safety barrier ground electrode.
9. Electronic equipment connected to associated apparatus must not use or generate more than 250 volts RMS.
10. Cable sets that are run together must have sufficient insulation to withstand 250 Volts RMS between sets.
11. All wiring must meet the requirements of the NEC or CEC Part I (whichever is applicable) and any local codes.



Part Number: 01-05 550980 Revision A

Temposonics, Level Plus and MTS are registered trademarks of MTS Systems Corporation.

All other trademarks are the property of their respective owners.

All Temposonics and Level Plus sensors are covered by US patent number 5,545,984. Additional patents are pending.

Printed in USA. Copyright © 2005 MTS Systems Corporation. All Rights Reserved.



UNITED STATES
MTS Systems Corporation
Sensors Division
3001 Sheldon Drive
Cary, NC 27513
Tel: (800) 457-6620
Fax: (919) 677-2545
(800) 943-1145
www.mtssensors.com
sensorsinfo@mts.com

GERMANY
MTS Sensor Technologie
GmbH & Co. KG
Auf dem Schüffel 9
D - 58513 Lüdenscheid
Tel: +49 / 23 51 / 95 87-0
Fax: +49 / 23 51 / 56 491
www.mtssensor.de
info@mtssensor.de

JAPAN
MTS Sensors Technology
Corporation
Ushikubo Bldg.
737 Aihara-cho, Machida-shi
Tokyo 194-0211, Japan
Tel: +81 (42) 775 / 3838
Fax: +81 (42) 775 / 5512
www.mtssensor.co.jp
info@mtssensor.co.jp